

Automation Is the Key to Meet Rising E-Commerce Consumer Demands

BUILD FOR TODAY.
INVEST FOR TOMORROW.



Explore the Future of Warehousing



GLOBAL E-COMMERCE SALES EXPECTED TO GROW \$8 TRILLION BY 2028



CHINA AND THE U.S. ARE THE LARGEST IN GLOBALE-COMMERCE, WITH SALES ABOVE \$2.32 TRILLION IN 2023



INCREASED DEMAND FOR WAREHOUSE SUPPORT

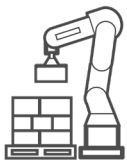
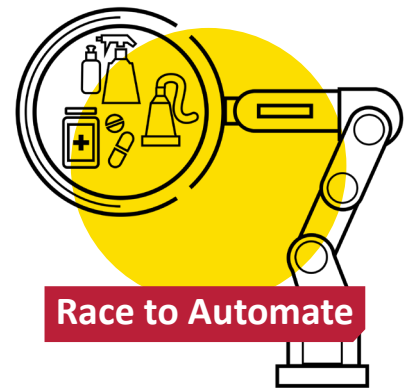

Today's digital consumer wants increasingly more products at lightning speeds. Your business needs fast, efficient and reliable processes to meet the growing demand in fulfillment.

Experts say the pandemic accelerated the shift to online shopping by as many as five years.



Your business' needs for these fast, efficient and reliable processes are urgent. E-commerce sales are projected to reach 1.9 trillion U.S. dollars by 2029.



E-COMMERCE MARKET REVENUE IN THE U.S. IS PROJECTED TO INCREASE



**BETWEEN 2024 AND 2029
54%**

**IN TOTAL
658
BILLION**

FULFILLMENT HELP DESPERATELY WANTED



**EXTRA
3.8 MILLION
EMPLOYEES**

Due to an aging workforce and shifting industry perception, manufacturing and logistics face a growing labor shortage. 3.8 million new manufacturing jobs are projected by 2033, with up to half potentially unfilled.



**MORE THAN
ONE THIRD
FACING SHORTAGES**

More than one third of logistics and supply chain management still face "high" or "extreme" labor shortages.

MORE JOBS WILL BE NEEDED AS E-COMMERCE SALES SKYROCKET—WITH TOO FEW EMPLOYEES TO FILL THEM.

Get Ahead with Innovative Order Fulfillment Systems

Businesses' inability to find enough employees has led them to turn to technology to not only keep pace with soaring demands for e-commerce goods but stand apart in speed, efficiency, productivity and cost containment.

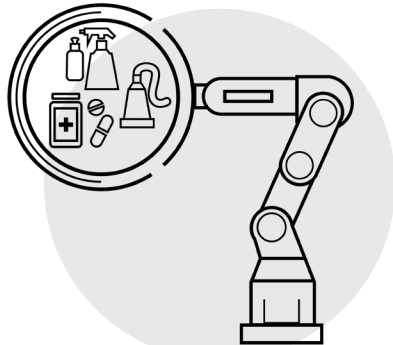

AUTOMATED STORAGE AND RETRIEVAL SYSTEMS ARE THE TICKET TO MAXIMIZING EFFICIENCY AND PRODUCTIVITY.



Most businesses don't require a completely automated solution. Many would benefit from having automation technology at the beginning and end of their fulfillment processes, helping with bringing in and getting out products.

Your business can improve your valuable employees' efficiency and safety levels by implementing automation solutions.



Direct-to-consumer fulfillment and return handling are expensive processes. Your business' success in an ultra-competitive and quickly changing landscape hinges on your efficiency.

INBOUND DEPALLETIZING AND OUTBOUND PALLETIZING

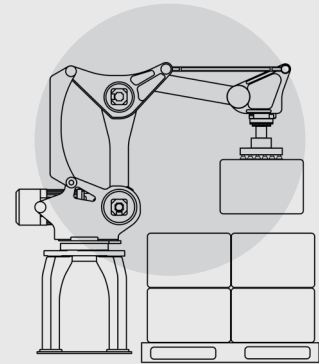

FANUC's palletizing robots can help streamline the beginning and end of your fulfillment processes by:

- ✓ Efficiently transporting materials in and out of your warehouse at world-class speeds.
- ✓ Using machine vision, sorting and height-detection technologies to depalletize homogeneous and heterogeneous loads.
- ✓ Palletizing differing products and SKUs onto the correct corresponding pallets.
- ✓ Handling dual-case palletizing for peak efficiency and throughput.
- ✓ Easily performing secondary functions such as layer forming, stretch wrapping, and slip sheet or pallet handling.
- ✓ Saving space, thanks to a footprint 30 to 50 percent more compact than most comparable automation systems.

Reap the Benefits of Automation

AUTOMATION PROVIDES FORWARD-THINKING BUSINESSES WITH THE OPPORTUNITY TO:



Manage inventory and trace product movement



Process orders 24/7



Reduce order fulfillment time



Increase order volumes



Optimize existing warehouse space



Ensure reliable and consistent picking and packing process

STORAGE AND RETRIEVAL SYSTEMS

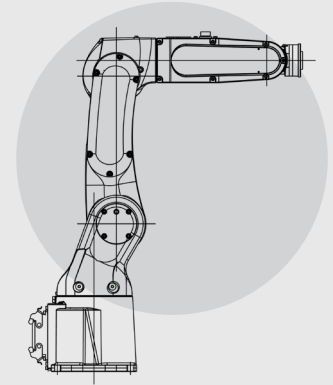

FANUC's storage and retrieval robots, including its *LR Mate 200iD/7L* robot, can help with:

- ✓ Tracking, managing and restocking more than 18,000 SKUs for products varying in size and shape.
- ✓ Covering a modular area, expandable in height and width, and occupying a small footprint.
- ✓ Serving customers unmanned with product selections directly through a kiosk.
- ✓ Elevating workflows in businesses, especially in the medical, manufacturing and retail industries.

Optimize Warehouse Space

AUTOMATED STORAGE AND RETRIEVAL SYSTEMS CAN HELP OPTIMIZE YOUR WAREHOUSE SPACE BY:

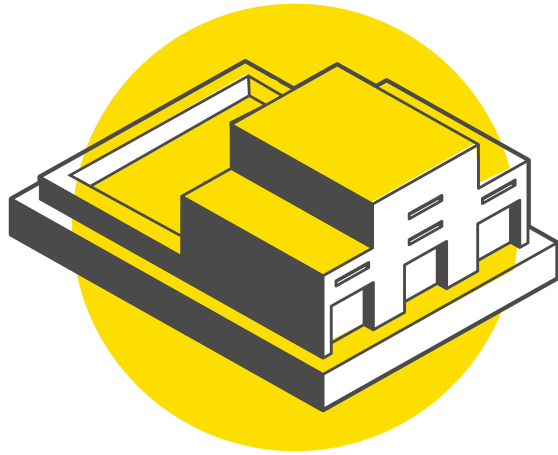

- ✓ Monitoring a vast warehouse section with a single robot.
- ✓ Handling more SKUs by lifting thousands of pounds.
- ✓ Increasing inventory by storing products vertically—as much as 125 feet high—while maximizing valuable and limited horizontal floor space.
- ✓ Streamlining inventory turns.
- ✓ Implementing and adapting processes using a modular structure.

LEVEL UP WITH VALUE-ADDED SERVICES

Automated facilities create opportunities for businesses to provide value-added services for their customers such as:

- Return handling
- Custom packaging
- Sortation
- Recycling
- Kitting
- Product routing
- Labeling

IMPROVE MANAGERS' ABILITY TO UTILIZE RESOURCES

With automation solutions, warehouse managers can:

- Ensure rapid responses to customers
- Better manage their inventories
- Efficiently utilize floor space
- Account for lack of labor for stocking and shipping

Sources

- <https://www.fanucamerica.com/industrial-solutions/industries-we-serve/warehousing-robots>
- <https://www.shopify.com/blog/global-ecommerce-sales>
- <https://www.statista.com/statistics/272391/us-retail-e-commerce-sales-forecast/>
- <https://www.capstonelogistics.com/blog/warehouse-operations-trends-2025/>
- <https://engage.descartes.com/descartes-insights/items/how-bad-is-the-supply-chain-and-logistics-workforce-challenge>