

M-20iB/25



Max. load capacity at wrist: 25 kg



Max. reach: 1853 mm

FANUC

Robot			Max. load capacity at wrist (kg)	Reach (mm)	Controlled axes	Repeatability (mm)	Mechanical weight (kg)	Motion range (°)						Maximum speed (°/s)						Moments (N-m)/Inertia (kg-m ²)			Protection		
Series	Version	Type						J1	J2	J3	J4	J5	J6	J1	J2	J3	J4	J5	J6	J4 Moment/Inertia	J5 Moment/Inertia	J6 Moment/Inertia	Average Power consumption (kW)	Body standard/optional	Wrist & J3 arm standard/optional
M-20	iB	25	25	1853	6	±0.02**	210	340 (360)	240	303	400	290	540	205	205	260	415	415	880	51/2.2	51/2.2	31/1.2	1	IP67	IP67

● standard ○ on request - not available ** Based on ISO9283

M-20iB/25

Standard model - 2 integrated solenoid valves

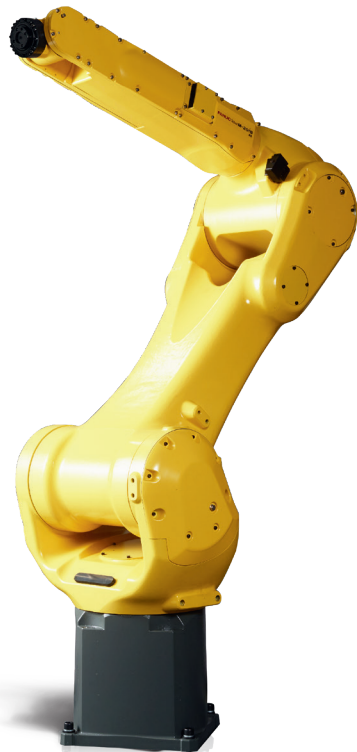

M-20iB/25

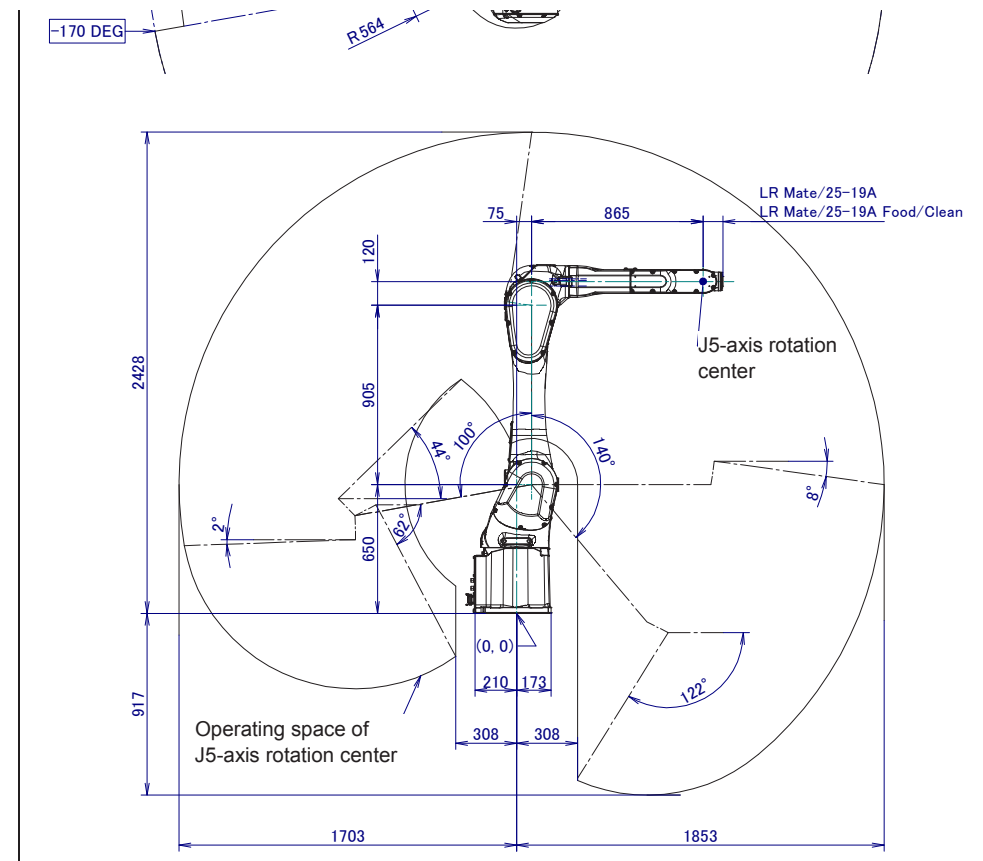

Fig. 3.2 (a) Operating space (M-20iB/25/25C)