

M-2iA/3SL



Max. load capacity at wrist: 3 kg



Max. reach: 1130 mm

FANUC

Robot			Max. load capacity at wrist (kg)	Reach (mm)	Controlled axes	Repeatability (mm)	Mechanical weight (kg)	Motion range (°)						Maximum speed (°/s)						J4 Moment/ Inertia	J5 Moment/ Inertia	J6 Moment/ Inertia	Average Power consumption (kW)	Protection	
Series	Version	Type						J1	J2	J3	J4	J5	J6	J1	J2	J3	J4	J5	J6					Body	Wrist & J3 arm
M-2	iA	3SL	3	1130	4	± 0.1	120	∅ 1130 X 400 (*3)			720	-	-	-	-	3500 1750(*3)	-	-	*4)	NA	2.5	IP69K	IP69K		

● standard ○ on request - not available *3) ∅ in mm by height in mm *4) refer to the wrist load diagram *5) high-inertia option

M-2iA/3SL

4-axis, long arm, hollow rotational wrist

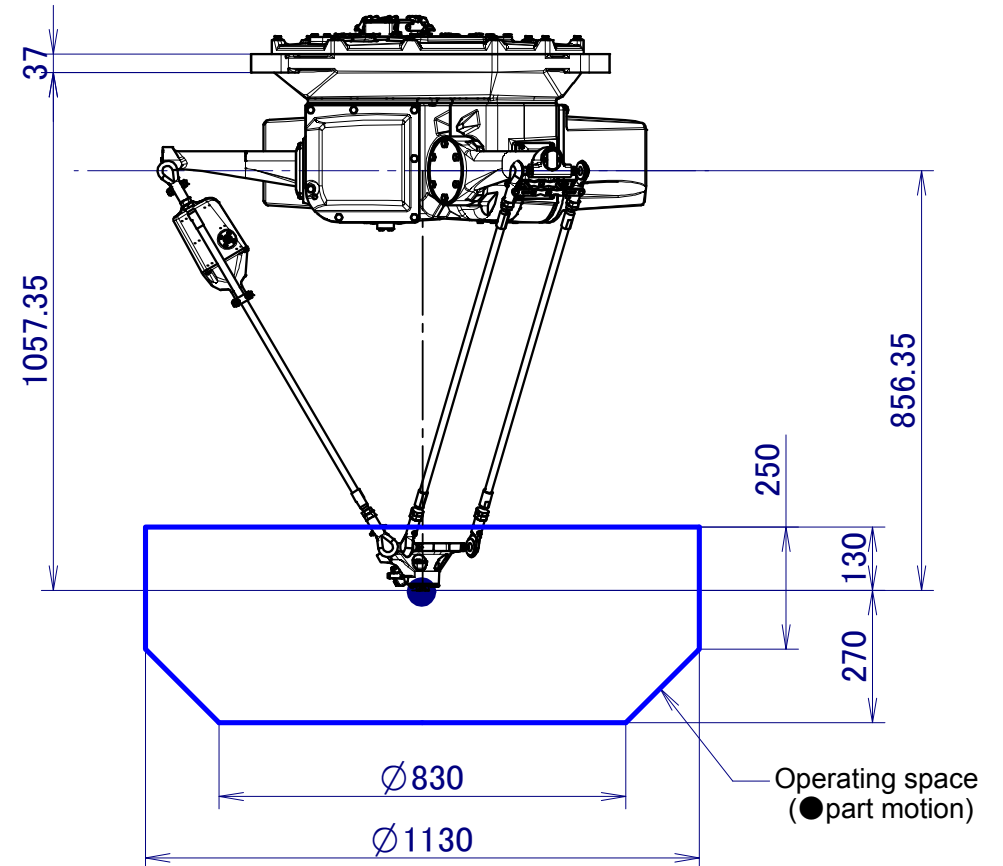

M-2iA/3SL