

SR-6iA/H



Max. load capacity at wrist: 6 kg



Max. reach: 650 mm

FANUC

Robot			Max. load capacity at wrist (kg)	Reach (mm)	Controlled axes	Repeatability (mm)	Mechanical weight (kg)	Motion range (°)						Maximum speed (°/s)						Moments (N-m)/Inertia (kg-m ²)			Protection		
Series	Version	Type						J1	J2	J3	J4	J5	J6	J1	J2	J3	J4	J5	J6	J4 Moment/Inertia			Push Force (N)	Body standard/optional	Wrist & J3 arm standard/optional
SR	iA/H	6	6	650	3	±0.01 [J1, J2] ±0.01 [J3]	28	±148	±150	210 mm*	-	-	-	440	700	2000 mm/s	-	-	-	,	,	,	200	IP20	IP20

- not available * z axis

SR-6iA/H 3-axis

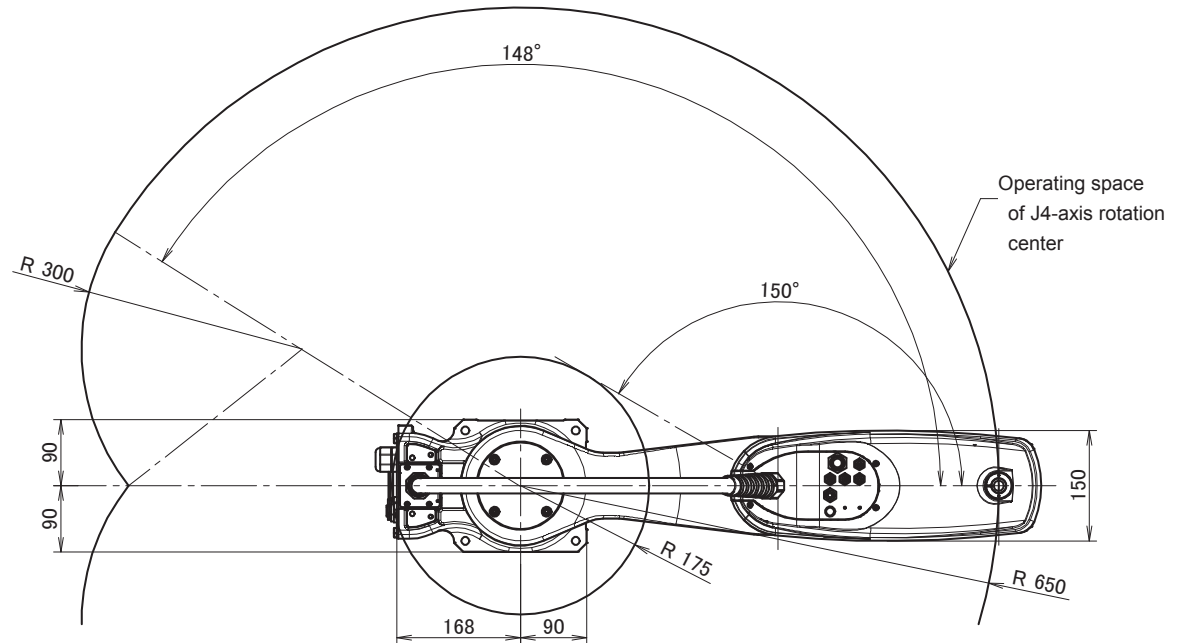

SR-6iA/H